

The Basic Notions of Sets and Functions

Notes for Math 261

Steve Bleiler and Bin Jiang

Department of Mathematics and Statistics
Portland State University

© September 2008

0 Introduction

Over the last few decades the basic theory of sets has become deeply embedded in modern mathematics; so deeply that many authors and instructors forget that many years of difficult mathematical reasoning went into set theory's development and take for granted that students have a solid understanding of these fundamental concepts. As a consequence, a formal unit on the basic theory of sets, boolean operations, products, quotients, and functions is missing from all too many curricula. These few pages are intended to offer those students who, for whatever reason, have not yet developed a working facility with these topics, a resource to aid in that development.

1 Sets

1.1 Basic Definitions

In mathematics, we frequently encounter collections of objects, be they points, lines, vectors, cabbages or kings. Many times the properties and behavior of the collections themselves are more important than those of the individual objects collected together. The fundamental type of collection is known as a set; and sets are those collections characterized by the objects contained within, the so-called elements of the set. When an object x is an element of some set X , we say x belongs to X and write $x \in X$.

For example, if the set $X = \{1, 2, 3\}$, we say that 1, 2, and 3 are the elements of X and write $1 \in X$, $2 \in X$, and $3 \in X$. To say that our set is characterized by the elements within

allows us to distinguish X from other sets such as, for example, $Y = \{1, 2, 3, 4\}$. We know that the sets X and Y are different because there is an element of Y , namely 4, which is not an element of X . If someone presents us with a set they call Z and in fact $Z = \{1, 2, 3\}$, then we know the sets X and Z are in fact equal (i.e. $X = Z$) because every element of Z is an element of X and every element of X is an element of Z . If you are asked to show that two sets are equal, this is exactly what you must do, show that every element of one is an element of the other and that every element of the other is an element of the one.

When we have sets $X = \{1, 2, 3\}$ and $Y = \{1, 2, 3, 4\}$ as above, where every element of X is an element of Y , but Y possibly has elements which do not belong to X , we say X is a subset of Y , or that Y includes X and write $X \subseteq Y$. Note that for all sets X , $X \subseteq X$. When Y contains every element of X and at least one other element not in X , we say Y strictly includes X and write $X \subset Y$. Another way to say that our sets are determined by their elements is:

Sets X and Y are equal if and only if X is a subset of Y and Y is a subset of X . In symbols, the above statement appears as

$$(X = Y) \Leftrightarrow ((X \subseteq Y) \text{ and } (Y \subseteq X))$$

Here a special set that frequently causes confusion deserves mention. This is the set that contains no elements at all, the so-called empty set which is typically denoted by \emptyset . Note that this special set is a subset of every set. Many times statements about general sets need special verification for the empty set. This is why you will find many references to non-empty sets, normally those sets that have at least one element, in the following pages. As $\emptyset \subseteq X$ and $X \subseteq X$ for every set X , we call \emptyset and X the improper subsets of X , and any other subset of X a proper subset.

Exercise 1: What non-empty sets have no proper subsets?

At this point in our discussion, it is worth noting the difference between ‘belonging’ \in and ‘including’ \subseteq . Typically, it is not true that an element of a set is also a subset of it. While this can happen (e.g. $\{\emptyset\}$ which is a set which is not empty as it contains the empty set as an element), it in general does not.

1.2 New Sets from Old

Given a set X , we wish to find ways to obtain new sets from it. A naive method is to consider subcollections, the subsets of X . Subsets of a given set are commonly obtained via specification, that is, an extra condition that the elements of X are meant to satisfy. A simple example is given when $X = \{1, 2, 3, 4, 5\}$ and our condition that the elements to be ‘subcollected’ are the even ones. The ‘specified’ set is then $\{2, 4\}$ and we indicate this set in symbols by $\{x \in X \mid x \text{ is an even integer}\}$. It is important to note that the sets obtained by specification depend strongly on the sets to which the specification is applied. For if our

larger set was $X' = \{1, 2, 3, 4, 5, 6\}$, the specification of an element to be an even integer produces the set $\{x \in X' \mid x \text{ is an even integer}\} = \{2, 4, 6\}$.

Early mathematicians somehow missed the importance of this larger set and believed that the specification itself determined a set. In a famous result, the so-called Russel paradox, the great logician and mathematician Bertrand Russel showed this to be false by showing the collection ‘determined’ by the specification ‘ X is a set’ is ‘too large’ to be a set itself. The proof of Russel’s remarkable result won’t be given here, you can find it in any good set theory text. In vernacular language Russel’s paradox tells us that it is not enough to have some ‘magic words’ to determine a set. One must already have a set in hand to which the ‘magic words’ apply.

1.3 Boolean Operations

Assume now, that all of our sets under discussion are subsets of some larger set E . Now it is easy to make new sets out of given ones through use of the logic operators ‘or’, ‘and’, ‘for some’, ‘for all’, and ‘not’ along with specification.

For sets A and B define their union $A \cup B$ as

$$\{x \in E \mid x \in A \text{ or } x \in B\}$$

Note that $A \subseteq A \cup B$ and $B \subseteq A \cup B$.

Taking the union is a way of ‘adding’ sets together. You may have seen that the so-called Venn Diagrams illustrating the concept where the shaded region illustrates $A \cup B$.

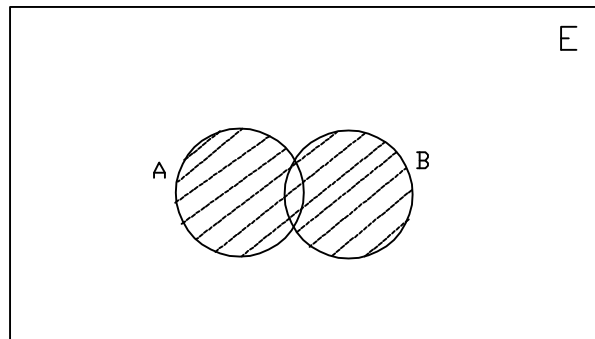

Of course we can take the union of an arbitrary number of sets by replacing the logic operator ‘or’ with ‘for some’. Let \mathcal{C} be a collection of subsets of our larger set E , then we define the union of the collection \mathcal{C} to be $\{x \in E \mid x \in X \text{ for some } X \in \mathcal{C}\}$ and denote this set by

$$\cup_{X \in \mathcal{C}} X.$$

Here are some facts about the union of sets that you should prove for yourself:

- 1) $A \cup \emptyset = A$
- 2) $A \cup B = B \cup A$
- 3) $A \cup (B \cup C) = (A \cup B) \cup C$
- 4) $A \cup A = A$
- 5) $A \subseteq B \Leftrightarrow A \cup B = B$

A second operation on sets is obtained by replacing ‘or’ and ‘for some’ in the above discussion with ‘and’ and ‘for all’ respectively. Here we can finesse out our larger set E by defining the intersection of sets A and B as the set $\{x \in A \mid x \in B\}$. Denote this new set by $A \cap B$ and note that the intersection $A \cap B$ also equals $\{x \in B \mid x \in A\}$ and $\{x \mid x \in A \text{ and } x \in B\}$. Here is the ‘intersection’ Venn Diagram where the shaded region represents $A \cap B$.

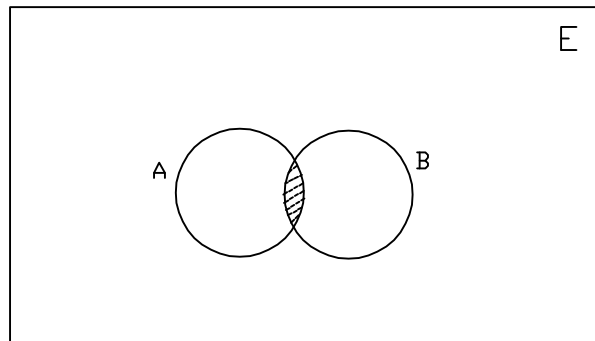

Here now are the basic facts about intersections, that you should also prove for yourself:

- 1) $A \cap \emptyset = \emptyset$
- 2) $A \cap B = B \cap A$
- 3) $A \cap (B \cap C) = (A \cap B) \cap C$
- 4) $A \cap A = A$
- 5) $A \subseteq B \Leftrightarrow A \cap B = A$

Given a non-empty collection \mathcal{C} of sets, we can find a set V that contains exactly those elements common to every set in the collection and nothing else. This is because we can find a set A in our collection and define

$$V = \{x \in A \mid x \in X \text{ for every } X \in \mathcal{C}\}.$$

Do not make the mistake of trying to define the intersection of an empty collection of sets. Such an object would be a collection of everything! (For any given object, find me a set in your empty collection that doesn't contain the object) Of course, Russel's paradox says such a collection could never be a set.

Returning to the intersections of non-empty collections \mathcal{C} of sets, we denote such by

$$\bigcap_{X \in \mathcal{C}} X.$$

In mathematics we find collections of sets with empty intersection often enough to give such collections a special name. We call two sets A and B with $A \cap B = \emptyset$ a disjoint pair of sets. The term is also used occasionally for larger collections of sets with empty intersection, but when any two sets of a collection are disjoint we call the collection pairwise disjoint to indicate this stronger condition.

Exercise 2: Produce a collection of three sets with empty intersection which is not pairwise disjoint.

Two useful formulas involving both unions and intersections are the Distributive Laws:

- 1) $A \cap (B \cup C) = (A \cap B) \cup (A \cap C)$
- 2) $A \cup (B \cap C) = (A \cup B) \cap (A \cup C)$

which again are formulas you should prove for yourself.

Exercise 3: Show that a necessary and sufficient condition for $(A \cap B) \cup C = A \cap (B \cup C)$ is that $C \subset A$. Note the condition has nothing to do with the set B .

Our next formulation of new sets from old involves the logic operator ‘not’. In particular for a subset A of our larger set E we consider the complement of A in E as the set

$$A^c = \{x \in E \mid x \text{ is not an element of } A\}.$$

You may have seen the Venn Diagram for this too:

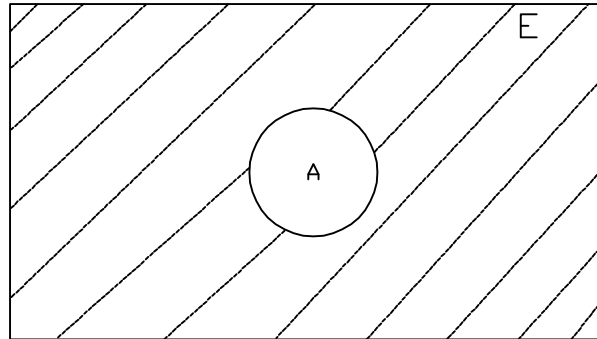

where the shaded region represents A^c . Most of the time our larger set E is clear from the context, so our notation for A^c should be clear. Here are the basic rules about complementation, which again you should prove for yourself

- 1) $(A^c)^c = A$
- 2) $\emptyset^c = E, E^c = \emptyset$
- 3) $A \cap A^c = \emptyset, A \cup A^c = E$
- 4) $A \subseteq B \Leftrightarrow B^c \subseteq A^c$

But by far the most important statements about complements are the DeMorgan Laws:

- 5) $(A \cup B)^c = A^c \cap B^c$
- 6) $(A \cap B)^c = A^c \cup B^c$

Note that these facts about sets indicate that valid formulas involving sets usually come in pairs. If in an inclusion or equation involving unions, intersections and complements of subsets of E we replace each set by its complement, interchange unions and intersections, and reverse inclusions, the result is another valid formula. This is known as the principle of duality.

Sometimes we don't care at all about a larger set E and only wish to know about elements of a given set A that are not elements of some other set B . For this we denote by $A - B$, the relative complement of B in A which is just the set

$$\{x \in A \mid x \text{ is not an element of } B\}.$$

It's time now to consider the collection of all subsets of a given set E . The axioms of set theory assert that this collection is again a set, called the power set of E and is denoted by $P(E)$. The set $P(E)$ then is just $\{A \mid A \subseteq E\}$.

Power sets are fairly 'large' when compared to their parent sets. For example, if $E = \emptyset$, $P(E) = \{\emptyset\}$; if $E = \{a\}$, then $P(E) = \{\emptyset, \{a\}\}$; if $E = \{a, b\}$, then $P(E) = \{\emptyset, \{a\}, \{b\}, \{a, b\}\}$. In general if E has n elements, then there are 2^n elements in $P(E)$.

Now if \mathcal{C} is a collection of subsets of E , that is, a subset of $P(E)$, then there is another natural collection \mathcal{D} of subsets of E , namely $\{X \mid X^c \in \mathcal{C}\}$. It is customary to denote the union and intersection of the collection \mathcal{D} as $\cup_{X \in \mathcal{C}} X^c$ and $\cap_{X \in \mathcal{C}} X^c$. With this notation the generalized DeMorgan Laws become

$$\begin{aligned} 1) \quad & (\cup_{X \in \mathcal{C}} X)^c = \cap_{X \in \mathcal{C}} X^c \\ 2) \quad & (\cap_{X \in \mathcal{C}} X)^c = \cup_{X \in \mathcal{C}} X^c \end{aligned}$$

and are once again something you should prove to yourself.

Exercise 4: Show $P(E) \cap P(F) = P(E \cap F)$ but $P(E) \cup P(F) \subseteq P(E \cup F)$ generally as proper subset.

1.4 Ordered Pairs

The elements of a set generally do not come in any specified order. For example, the pair $\{a, b\}$ is clearly equal to the pair $\{b, a\}$ as sets. We wish to impose a little more structure and be able to speak about the ordered pair (a, b) , with first coordinate a , and second coordinate b . One way to accomplish this is to add 'something' to the pair $\{a, b\}$ that gives the 'ordering'. For us, this 'something' is just the information that tells us which of the two elements of our pair comes first. So define the ordered pair (a, b) to be the set $\{\{a, b\}, \{a\}\}$.

This definition looks artificial, and it is. However, it has the advantage of defining an ordered pair as a set, and though we will not be giving the proofs here, allows the mathematician to prove the following fundamental properties of ordered pairs using only the Boolean operations we have just considered.

What are these properties? The first and most important is that ordered pairs are equal exactly when their first coordinates are equal and their second coordinates are equal as well. In symbols this says that $(a, b) = (c, d)$ if and only if $a = c$ and $b = d$.

Second, given sets A and B , there exists a unique set, called $A \times B$ that consists exactly of all the ordered pairs of form (a, b) with $a \in A$ and $b \in B$. This set is called the Cartesian product of A and B . In our study of linear algebra we will frequently be examining the Cartesian product of many sets, considering ordered triples, quadruples, and the like.

The Cartesian product is a set of ordered pairs, i.e. a set whose elements are all ordered pairs, the same is true of any subset of a cartesian product. It is of technical importance to know that we can go the other way, that is, to know that every set of ordered pairs is a subset of the Cartesian product of some two sets. In other words, if R is a set of ordered pairs, then there are sets A and B with $R \subset A \times B$. For this we set $A = \{a \mid \text{for some } b, (a, b) \in R\}$ and $B = \{b \mid \text{for some } a, (a, b) \in R\}$. These sets are called the projections of R onto the first and second coordinates respectively.

Exercise 5: if A, B, X and Y are sets then

- 1) $(A \cup B) \times X = (A \times X) \cup (B \times X)$
- 2) $(A \cap B) \times X = (A \times X) \cap (B \times X)$
- 3) $(A - B) \times X = (A \times X) - (B \times X)$

Further, if either $A = \emptyset$ or $B = \emptyset$, then $A \times B = \emptyset$ and conversely. Finally, if $A \subset X$ and $B \subset Y$, then $A \times B \subset X \times Y$ and (if $A \times B \neq \emptyset$) conversely.

1.5 Relations

By a relation in mathematics we mean a correlation between two collections of objects. Not surprisingly this takes the form of a set of ordered pairs. A set R is a relation if every element of R is an ordered pair. Of course, this means for every $r \in R$, $r = (x, y)$ and we typically write xRy and say that x stands in relation R to y .

The most boring relations are the empty one \emptyset and a Cartesian product $X \times Y$. More interesting is the relation in $X \times X$ given by $\{(x, x) \mid x \in X\}$ which is the relation of equality. ‘Belonging’ can be expressed as a relation in $X \times P(X)$. Just consider the pair (x, A) to be in your relation exactly when $x \in A$.

You may recall the two sets that we defined above for any relation R . These sets are known as the domain and image of R respectively and denoted by $\text{dom } R$ and $\text{Im } R$. In particular, these sets are defined by

$$\begin{aligned}\text{dom } R &= \{x \mid \text{for some } y, xRy\} \\ \text{Im } R &= \{y \mid \text{for some } x, xRy\}\end{aligned}$$

If $R = \emptyset$, then both $\text{dom } R$ and $\text{Im } R$ are empty as well, if $R = X \times Y$ then $\text{dom } R = X$ and $\text{Im } R = Y$, if R is equality in X then $\text{dom } R = \text{Im } R = X$. If R is belonging, then $\text{dom } R = X$ and $\text{Im } R = P(X)$.

When R is a relation which is a subset of $X \times Y$, i.e. $\text{dom } R \subset X$ and $\text{Im } R \subset Y$, we sometimes say R is a relation from X to Y . When $X = Y$, instead of saying that R is a relation from X to X , we say R is a relation in X . A relation R in X is reflexive if xRx for every $x \in X$, symmetric if xRy implies that yRx , and transitive if xRy and yRz imply that xRz .

Exercise 6: Find relations that have any two of these properties, but not the third.

A relation R that is reflexive, symmetric and transitive is called an equivalence relation. The smallest equivalence relation in X is I , the largest is $X \times X$. An equivalence relation is frequently denoted by " \sim ".

A partition of X is a pairwise disjoint collection \mathcal{C} of non-empty subsets of X whose union is X . These collections are intimately connected to equivalence relations. If \sim is an equivalence relation in X , and if $x \in X$, the equivalence class of x with respect to \sim is

$$[x]_{\sim} = \{y \mid y \sim x\}$$

If say \sim is I , the equivalence classes are all singletons. Note that for any equivalence relation, the set of equivalence classes forms a partition of X . This set of equivalence classes is usually denoted by X/\sim and reads as " X modulo \sim " or " $X \text{ mod } \sim$ ". Note too that given a partition \mathcal{C} of X we can form the induced equivalence relation \sim_c by declaring that $x \sim_c y$ if and only if they are elements of the same member of \mathcal{C} .

Exercise 7: Let $X = \{a, b, c, d\}$. Show that $R = \{(a, a), (b, b), (c, c), (d, d), (a, b), (b, a)\}$ is an equivalence relation in X .

2 Functions

2.1 Definition of Functions

The notion of function is central to mathematics and appears in the various areas of mathematics under various synonyms such as map or mapping, transformation, correspondence, or operator. A function is a special way of relating the members of one set X , called the domain, to the members of another set Y , called the range. The special way of relating the elements of the domain to the elements of the range is that to each (and every) element x of the domain we associate a unique element y in the range.

You've probably seen functions before, particularly when the domain and range were sets of numbers and the 'function' was a formula which described how to get a second number from the first, something like $f(x) = x^2 + 1$, or $f(x) = x \sin x + 11$. From such a formula you were likely shown how to graph a function by writing down a collection of ordered pairs of form $(x, f(x))$ and then drawing the 'picture'. For $f(x) = x^2$ this looks like

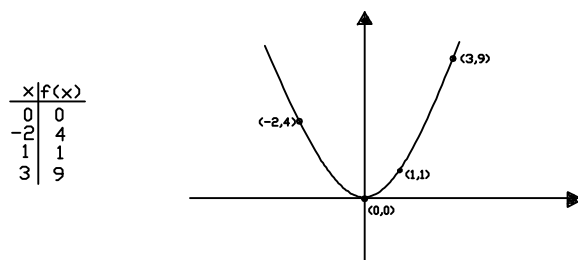

To mathematicians, the function is the graph as indicated by the following definition:

A function f from a set X into a set Y is a relation from X to Y such that $\text{dom } f = X$ and such that if (x, y) and (x, z) are elements of f , then $y = z$.

This definition of function has the advantage of being precise in the set theoretic sense which helps in resolving some common confusions about functions. One such confusion arises from the fact that the range of a function might be larger than its image. You see this for our function $f(x) = x^2$ above. For many applications, it is useful to consider the range of f to be the set of all real numbers \mathbb{R} (including the negative ones) while the image of f is just the non-negative reals. (Recall $\text{Im } f = \{y \mid \text{for some } x, (x, y) \in f\}$).

Functions whose image equals their range are called onto functions or described (from the French) as being surjective. Another way that a function can be special is for it to have the property that if (x, y) and (z, y) are in f , then $x = z$. Such functions are called one-to-one (1-1) functions or (again from the French) injective. Note as functions from the real numbers to themselves the function $f(x) = x^2$ is not injective while the function $g(x) = x^3$ is.

If X is a subset of a set Y , the function $i_X : X \rightarrow Y$ defined by $i_X(x) = x$ for each x is called the inclusion map of X into Y . The inclusion map of X into itself is called the identity map and is usually denoted by 1_X . Note that in the language of relations the identity map is just the relation I . If again X is a subset of Y there is a natural connection between the inclusion map of X into Y and the identity map of Y ; that connection exemplifies the general procedure for making small functions out of big ones. If f is a function from Y to Z and X is a subset of Y we construct a new function g from X to Z with the property that $g(x) = f(x)$ for each $x \in X$. This new function g is called the restriction of f to X and f is called an extension of g to Y . The function g is typically written as $f|_X$ as in $f|_X(x) = f(x)$. In this notation, the inclusion map $i_X : X \rightarrow Y$ becomes $(1_Y|_X)(x) = i_X(x) = x$. Note inclusion and identity maps are one-to-one.

Here now are some functions you'll be using a lot in the linear algebra section that follows. For sets X and Y define a function p_X from $X \times Y$ to X by taking $p_X(x, y) = x$. This function p_X is called the projection map from $X \times Y$ onto X , the first coordinate. Similarly, the function p_Y from $X \times Y$ onto Y , the second coordinate, is given by $p_Y(x, y) = y$. Similar projection maps are defined for Cartesian products with any number of factors.

A slightly more difficult but very useful function exists in the presence of an equivalence

relation \sim on a set X . Given an equivalence relation \sim on X , define the function p_\sim from X to X/\sim by setting $p_\sim(x) = [x]_\sim$ the equivalence class of x under \sim . This function is called the canonical map from X to X/\sim . Note p_\sim is onto. Further, any function $f : X \rightarrow Y$ defines an equivalence relation \sim on X by setting $x_1 \sim x_2$ exactly when $f(x_1) = f(x_2)$. Note that X/\sim is then in 1-1 correspondence with $\text{Im } f$.

2.2 Inverses and Composites

Given a function $f : X \rightarrow Y$ we can easily ‘lift’ f to a function, historically also called f , which maps the power set $P(X)$ to the power set $P(Y)$. This function takes a subset A of the domain X of f to the image subset $f(A)$ defined as $\{y \mid \text{for some } x \in A, f(x) = y\}$. contained in the range Y .

The behavior of this lifted f with respect to the Boolean operations of union, intersection, and complement is poor. While it is true that for a collection of subset \mathcal{C} of the domain $f(\cup_{A \in \mathcal{C}} A) = \cup_{A \in \mathcal{C}} f(A)$, it is false in general that $f(\cap_{A \in \mathcal{C}} A) = \cap_{A \in \mathcal{C}} f(A)$ and even if f is onto, it is not generally true that $f(X - A) = Y - f(A)$.

Exercise 8: Verify these assertions.

However, given a correspondence between elements of X and those of Y , one can find a well-behaved correspondence between the subsets of X and those of Y by moving ‘backwards’ through the formation of inverse images, rather than as above moving ‘forwards’ through the formation of images. In particular, given a function $f : X \rightarrow Y$, define f^{-1} , the inverse of f , as the function from $P(Y)$ to $P(X)$ such that if $B \subset Y$, then $f^{-1}(B) = \{x \in X \mid f(x) \in B\}$. Call the set $f^{-1}(B)$ the inverse image of B under f and note it is exactly that subset of the domain that f maps into B .

Exercise 9: A necessary and sufficient condition that f is 1-1 is that for each singleton subset of the image of f , the inverse image is a singleton subset of the domain.

Exercise 10: A necessary and sufficient condition that f is onto is that the inverse image of each non-empty subset of the range is a non-empty subset of the domain.

When $f : X \rightarrow Y$ is 1-1, historically f^{-1} has been given another meaning, at odds with the one above, namely the function whose domain is the image of f and whose image is X , and whose value at each point y in $\text{Im } f$ is the unique $x \in X$ which is mapped to it under f . While many students find this confusing, its practice is so ingrained in the mathematical literature that nothing now can be done about it. One needs to learn how to recognize which interpretation of f^{-1} is used from the context.

Here are a few important properties of images and inverse images that you should verify

for yourself:

- 1) If $B \subset Y$, then $f(f^{-1}(B)) \subseteq B$ and if f is onto, $f(f^{-1}(B)) = B$
- 2) if $A \subset X$, then $A \subseteq f^{-1}(f(A))$ and if f is 1-1, $A = f^{-1}(f(A))$.

In particular, f^{-1} behaves nicely with respect to our Boolean operations, i.e.

- 3) $f^{-1}(\bigcup_{B \in \mathcal{C}} B) = \bigcup_{B \in \mathcal{C}} f^{-1}(B)$
- 4) $f^{-1}(\bigcap_{B \in \mathcal{C}} B) = \bigcap_{B \in \mathcal{C}} f^{-1}(B)$
- 5) $f^{-1}(Y - B) = X - f^{-1}(B)$.

Finally, it is worth knowing that under favorable circumstances functions can be combined in a manner reminiscent of multiplication. Specifically if f is a function from X to Y and g is a function from Y to Z we can form their composite $g \circ f$ (read 'g following f') by setting $(g \circ f)(x) = g(f(x))$. Note that like the actions of 'putting on socks' and 'putting on shoes', what you get from composing functions depends on the order in which you compose them. In fact, depending on f and g , it may not be possible to form both $g \circ f$ and $f \circ g$. Even when we can, the two compositions may be quite different. As an example, let $X = Y = R$ the real numbers, let $f(x) = x^2$, $g(x) = 3x + 1$, then $(g \circ f)(x) = g(x^2) = 3x^2 + 1$ and $(f \circ g)(x) = f(3x + 1) = (3x + 1)^2 = 9x^2 + 6x + 1$.

Exercise 11: Suppose $f : X \rightarrow Y$ and $g : Y \rightarrow X$ such that $g \circ f = 1_X$. Show that f is 1-1 and g is onto.

This concludes our review of the basic notions of sets and functions.

3 Additional Exercises

1. (Sets) Let \mathbb{N} be the set of all positive integers. Determine its subsets $A = \{x \in \mathbb{N} \mid x \text{ is odd and } x \leq 12\}$ and $B = \{x \in \mathbb{N} \mid 3 \text{ divides } x \text{ and } x \leq 20\}$. What are $A \cap B$ and $A - B$?
2. (Sets) Let $E = \{1, 2, 3, 4, 5, 6, 7, 8, 9, 10\}$, $A = \{1, 2, 3, 4\}$, $B = \{2, 4, 6, 8\}$, $C = \{3, 4, 5, 6\}$. Find (1) $A \cap B \cap C$, (2) $A - B$, (3) $(A \cup B)^c$, (4) $A^c \cup B^c \cup C^c$. Then use (1) and (4) to verify DeMorgan Law $(A \cap B \cap C)^c = A^c \cup B^c \cup C^c$.
3. (Sets) Use Venn diagram to show that if $A \cap B = \emptyset$, then $A \subset B^c$.
4. (Sets) Draw a Venn diagram for three non-empty sets A , B and C so that $A \cap B \neq \emptyset$, $B \cap C \neq \emptyset$ but $A \cap C = \emptyset$.
5. (Sets) Let $A = \{a, b\}$, $B = \{2, 3\}$ and $C = \{3, 4\}$. Find
 - (1) $A \times (B \cup C)$,
 - (2) $(A \times B) \cup (A \times C)$,
 - (3) $A \times (B \cap C)$,
 - (4) $(A \times B) \cap (A \times C)$

6. (Ordered Pairs) Suppose $(y - 2, 2x + 1) = (x - 1, y + 2)$. Find x and y .
7. (Ordered Pairs) Let $W = \{\text{Mark, Eric, Paul}\}$ and $V = \{\text{Eric, David}\}$. Find $W \times V$, $V \times W$ and $V \times V$.
8. (Relations) Let R be the relation from $A = \{1, 2, 3, 4\}$ to $B = \{1, 3, 5\}$ which is defined by the sentence ' x is less than y '. Write R as a set of ordered pairs and find its domain and range.
9. (Relations) Let R be the relation from $E = \{2, 3, 4, 5\}$ to $F = \{3, 6, 7, 10\}$ which is defined by the sentence ' x divides y '. Write R as a set of ordered pairs and find its domain and range.
10. (Relations) Let $E = \{1, 2, 3, 4, 5\}$. Verify the relation

$$R = \{(1, 1), (1, 2), (2, 1), (2, 2), (3, 3), (3, 4), (4, 3), (4, 4), (5, 5)\}$$

is an equivalence relation in E . What is the corresponding partition of E based on such R ?

11. (Relations) Let R be the relation in the set of natural numbers \mathbb{N} defined by the sentence ' $(x - y)$ is divisible by 2', that is,

$$R = \{(x, y) \mid x \in \mathbb{N}, y \in \mathbb{N}, 2 \mid (x - y)\}.$$

Show that R is an equivalence relation.

12. (Functions) Let $X = \{-2, -1, 0, 1, 2\}$. Let the function $g : X \rightarrow \mathbb{R}$ be defined by the formula $g(x) = x^3 + 1$. Find the image of g . Is the function one-to-one? If so, find its inverse.

13. (Functions) Let the functions $f : A \rightarrow B$ and $g : B \rightarrow C$ be defined by the diagram

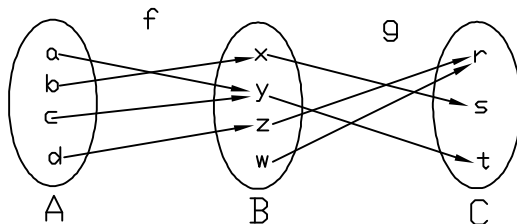

Find the composite $g \circ f : A \rightarrow C$, then determine the ranges of f , g and $g \circ f$.

14. (Functions) Let $A = \{a, b, c, d\}$. Show that the set $\{(a, b), (b, d), (c, a), (d, c)\}$ is a one-to-one, onto function of A into A . Find its inverse function.
15. (Inverses and Composites) Let $f(x) = \sin(x)$, $g(x) = e^{2x}$ and $h(x) = x^3 + 1$. Determine the following composites: $f \circ g$, $g \circ f$, $f \circ g \circ h$ and $h \circ g \circ f$.